



## Features

- Dual axis measurement, range :  $\pm 45^\circ$
- Solid state MEMS sensor
- RS232 full duplex communication (TTL level UART output available on request)
- Low cost (<£25 for 1kpcs)
- Zero offset position can be easily programmed and stored
- Programmable frequency response between 0.125 and 32Hz
- Onboard temperature sensor
- Small size, 46 x 39 x 10.5mm, with a 10m cable
- Sealed to IP67



## Applications

- PV solar tracker control systems
- Platform levelling and monitoring
- GPS compensation
- Platform scales and weigh bridge levelling
- Agricultural and industrial vehicle tilt monitoring
- Telescopic and scissor lift platform monitoring
- Can be readily customised to suit most applications

## Description

The LCH-45-02 is a low cost dual axis inclinometer sensor supplied in a sealed machined Aluminium housing. It has a digital interface with a full duplex RS232 output for connection directly to a serial port. A PCB only version is also available (part number LCP-45). These devices are manufactured and calibrated in our UK factory to guarantee performance to the stated specification.

## Specifications

Parameter	Value	Unit	Notes
<b>Supply Voltage</b>	4.9 to 15	V dc	Supply voltage is protected internally against reverse polarity, and supply transients. On request this unit can be supplied configured for 3.3V operation.
<b>Operating Current</b>	18	mA	Maximum value at any operating voltage in range. Low power version (<2mA) can be configured on request.
<b>Operating Temperature</b>	-40 to 85	$^\circ\text{C}$	Maximum operating temperature range. Temperature variation will cause measurement errors as defined below.
<b>Measuring range</b>	$\pm 45$	$^\circ$	Direction of measurement can be reversed and zero position can be reset anywhere in range. Settings are stored in non volatile memory so are remembered after power down.
<b>Resolution (@1Hz BW)</b>	0.05	$^\circ$	Resolution is the smallest measurable change in output.
<b>Zero Bias Error</b>	$\pm 0.1^\circ$	$^\circ$	This is the maximum error when the device is mounted on a level surface when the device is at room temperature ( $20^\circ\text{C}$ )
<b>Accuracy (@<math>20^\circ\text{C}</math>)</b>	$\pm 0.3$	$^\circ$	This is the maximum error between the measured and displayed value at any point in the measurement range when the device is at room temperature ( $20^\circ\text{C}$ )
<b>Temperature Error</b>	0.01	$^\circ/\text{C}$	This is the maximum change in output per $^\circ\text{C}$ change of temperature.
<b>Accuracy (-20 to <math>70^\circ\text{C}</math>)</b>	$\pm 1$	$^\circ$	This is the maximum error between the measured and displayed value at any point in the measurement range at any temperature over the specified temperature range.
<b>RS232 Output Rate</b>	38400	bps	Bit rate is adjustable between 115.2k, 57.6k, 38.4k, 19.2k and 9.6k, 4.8k and 2.4k via the digital interface
<b>RS232 Data Format</b>	38.4, 8,1,n		1 start bit, 8 data bits, 1 stop bit, no parity
<b>Low Pass Filter Freq.</b>	1	Hz	Features a low pass filter which is adjustable between 32Hz & 0.125Hz via the control commands, see page 4 for more details. The default setting is 1Hz.
<b>Mechanical shock</b>	3000 (0.5ms) 10000 (0.1ms)	g	Shock survival limit for MEMS sensor.
<b>Cable Length</b>	10	m	Other lengths available on request
<b>Weight</b>	24	g	Not including cable



Dimension Drawing

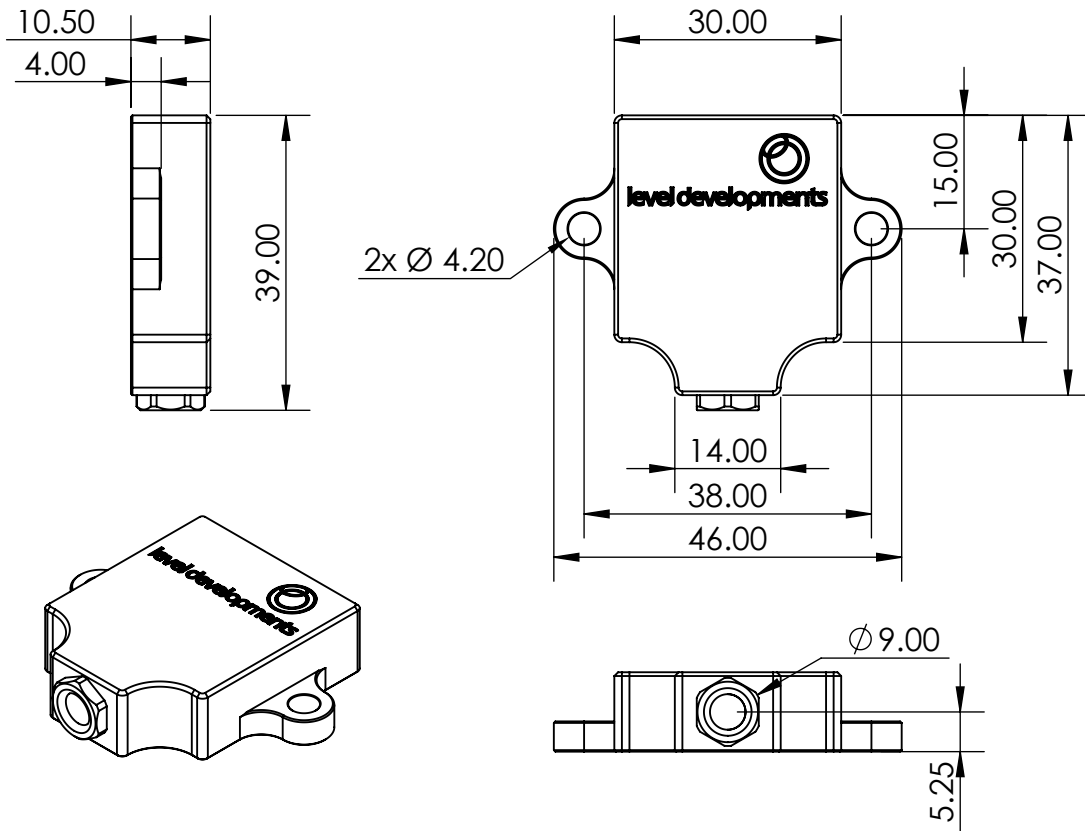

Axis Direction and Mounting Orientation

Mounted on Horizontal Surface

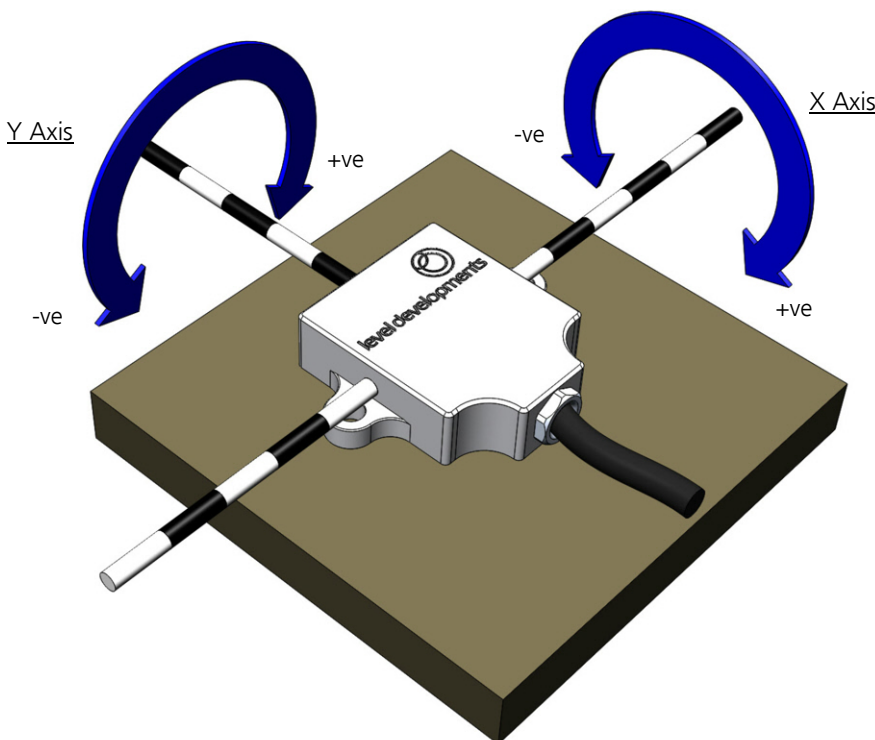

Wire Colour	Function
Red	+Ve Supply
Blue	GND
Yellow	RS232 Tx
Green	RS232 Rx



### Cable Details

Standard cable is 10m long. Cables can be supplied in any length up to 100m. The maximum length of cable that RS232 can transmit over depends on many factors, such as the baud rate, the method of termination, the type of cable, the surrounding electrical noise, and the type of transceiver at the other end of the cable. We have tested this device connected with a serial port of a PC at 9600 baud over 100m of the cable specified below in a low noise environment.

1. Core wires, tin plated copper, 18x0.1mm strands per conductor (26 AWG).
2. 4 conductors, colours red, blue, yellow and green. PVC core insulation.
3. Braided screen of tin copper wire with minimum 85% coverage.
4. Black PUR Solar jacket. Flame retardant, reduced smoke generation, zero halogen, excellent for use in water and oil, good for use in acids and fuels, radiation tolerance: 10E6 Gy, UV stable, suitable for continuous outdoor use.

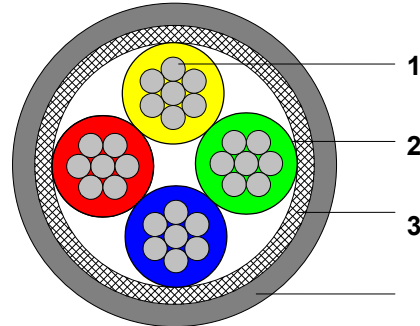

Parameter	Value	Unit	Notes
Approximate Weight	40	g/m	
Operating Temperature	-20 to 70	°C	
Conductor Resistance	100	Ω/Km	Maximum resistance
Insulation Resistance	1500	MΩ/Km	Minimum resistance
Test Voltage	1	KV DC	
Voltage Rating	250	V	
Core Current Rating	0.5	A	At 40°C air temperature
Individual Core Diameter	1.1	mm	
Overall Diameter	4.5	mm	

Internal Wire Colour	Function
Red	+ve Supply
Blue	Ground
Yellow	RS232 Tx
Green	RS232 Rx

### Certification

The products are type approved to in accordance with the following directive(s):

EMC Directive 2004/108/EC

And it has been designed, manufactured and tested to the following specifications:

BS EN61326-1:2006

Electrical equipment for measurement, control and laboratory use – EMC Requirements

BS EN55011:2007, Group 1 Class B



Certification is available on request.

### Product Options

1. The standard product has an RS232 interface, however an RS485 version is available as a special order item.
2. Standard cable length is 10m, others are available on request as a special order item.
3. Standard supply voltage is 4.9-15Vdc. A 3.3V supply option is available on request as a special order item.
4. Standard communication protocol is with the Level Developments simplified command set (see page 4). A ModBus version is available as a special order item, and custom protocols can be configured on request.

Special order versions are generally only available for volume orders or ongoing requirements.



**Control Command Set**

Data is transmitted and received over RS232 in full duplex mode. The default configuration is with the baud rate set to 38.4kbps, with 8 data bits, 1 stop bit and no parity. All commands are lower case and 7 bytes long. The time between each character of the command must be less than 100ms otherwise the device will discard the command. The settings are all stored in non volatile memory.

Command	Description	Response Length	Response
get---x	Returns the X axis angle as either: - An INT32 value equal to the angle x 1000 - A fixed length ASCII string terminated with a carriage return depending on the setting of commands 'setoasc' or 'setoint' Shipping default is INT32.	4 bytes 9 bytes	&h XX XX XX XX +025.430<CR>
get---y	Returns the Y axis angle as either: - An INT32 value equal to the angle x 1000 - A fixed length ASCII string terminated with a carriage return depending on the setting of commands 'setoasc' or 'setoint' Shipping default is INT32.	4 bytes 9 bytes	&h YY YY YY YY +025.430<CR>
get-x&y	Returns the X and Y axis angle (X is transmitted first) as either: - A pair of INT32 value equal to the angle x 1000 - A fixed length comma separated ASCII string terminated with <CR> depending on the setting of commands 'setoasc' or 'setoint' Shipping default is INT32.	8 bytes 18 bytes	&h XX XX XX XX YY YY YY YY $\pm$ xxx.xxx, $\pm$ yyy.yyy<CR>
gettemp	Returns the temperature of the sensor as either: - An INT16 value equal to the temperature x 100 - A fixed length ASCII string terminated with a carriage return depending on the setting of commands 'setoasc' or 'setoint' Shipping default is INT32.	2 bytes 6 bytes	&h XX XX $\pm$ tt.t<CR>
str9999	Set continuous output transmission rate in milliseconds (50-9999ms) - str0100 - 100ms (0.1s) between transmissions - str8500 - 8500ms (8.5s) between transmissions	2 bytes	OK
setcasc	Sets the output to transmit the X and Y angle continuously in ASCII format at the rate defined by strXXXX.	18 bytes	$\pm$ xxx.xxx, $\pm$ yyy.yyy<CR>
stpcasc	Stops the continuous transmission of ASCII data	2 bytes	OK
get-flt	Returns the value of the current filter time constant in ms as an INT16	2 bytes	&h XX XX
setdir1	Sets the X axis measurement direction to positive clockwise	2 bytes	OK
setdir2	Sets the X axis measurement direction to negative clockwise	2 bytes	OK
setdir3	Sets the Y axis measurement direction to positive clockwise	2 bytes	OK
setdir4	Sets the Y axis measurement direction to negative clockwise	2 bytes	OK
setzcur	Tare function to set the current position to zero	2 bytes	OK
setzfac	Cancel tare function and resets zero to factory setting	2 bytes	OK
setoasc	Sets the output to ASCII format	2 bytes	OK
setoint	Sets the output to Integer format	2 bytes	OK
setflt1	Sets the digital filter frequency response to 0.125Hz	2 bytes	OK
setflt2	Sets the digital filter frequency response to 0.25Hz	2 bytes	OK
setflt3	Sets the digital filter frequency response to 0.5Hz	2 bytes	OK
setflt4	Sets the digital filter frequency response to 1Hz	2 bytes	OK
setflt5	Sets the digital filter frequency response to 2Hz	2 bytes	OK
setflt6	Sets the digital filter frequency response to 4Hz	2 bytes	OK
setflt7	Sets the digital filter frequency response to 8Hz	2 bytes	OK
setflt8	Sets the digital filter frequency response to 16Hz	2 bytes	OK
setflt9	Sets the digital filter frequency response to 32Hz	2 bytes	OK
set-br1	Sets the BAUD rate to 2400bps	2 bytes	OK
set-br2	Sets the BAUD rate to 4800bps	2 bytes	OK
set-br3	Sets the BAUD rate to 9600bps	2 bytes	OK
set-br4	Sets the BAUD rate to 19200bps	2 bytes	OK
set-br5	Sets the BAUD rate to 38400bps	2 bytes	OK
set-br6	Sets the BAUD rate to 57600bps	2 bytes	OK
set-br7	Sets the BAUD rate to 115200bps	2 bytes	OK



### Software

A free Windows based application for reading angle, logging and device configuration is available from our website. It requires Windows XP SP3, Windows 7 or Windows 8, and works with 32 and 64 bit systems. It also requires the .net framework V3.5 or higher, and will prompt you to download and install this from Microsoft if it is not already installed on your system. A COM port is also required, and can either be a built in COM port, or a USB to Serial COM port.

The basic features are shown below:

- Automatic or manual configuration of COM port parameters
- Compatible with single or dual axis sensors
- Adjustable number of decimal places on displays
- Logging of data at specified intervals into CSV file
- Setting device to absolute or relative measurement mode
- Switching the data transfer protocol between Integer and ASCII
- Changing the frequency response of the sensor
- Changing the Baud rate of the sensor

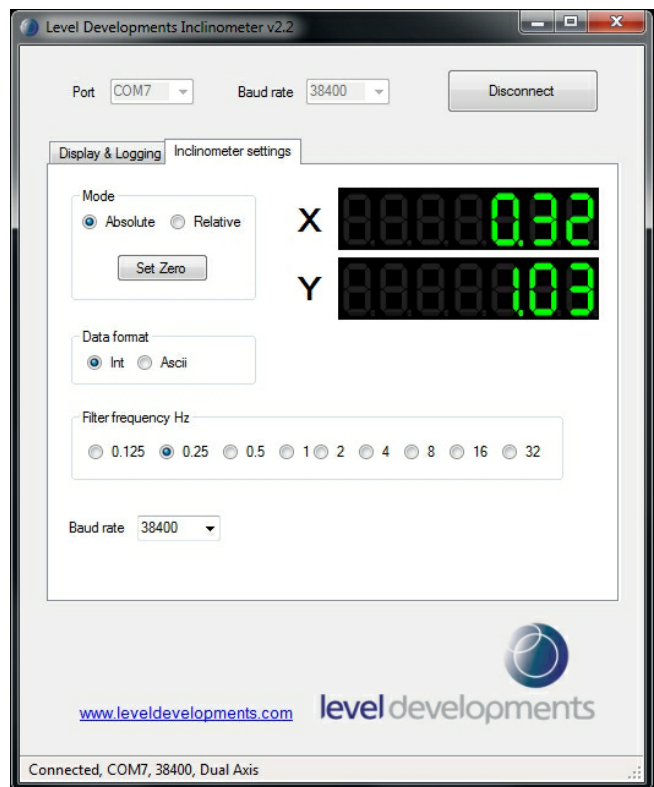
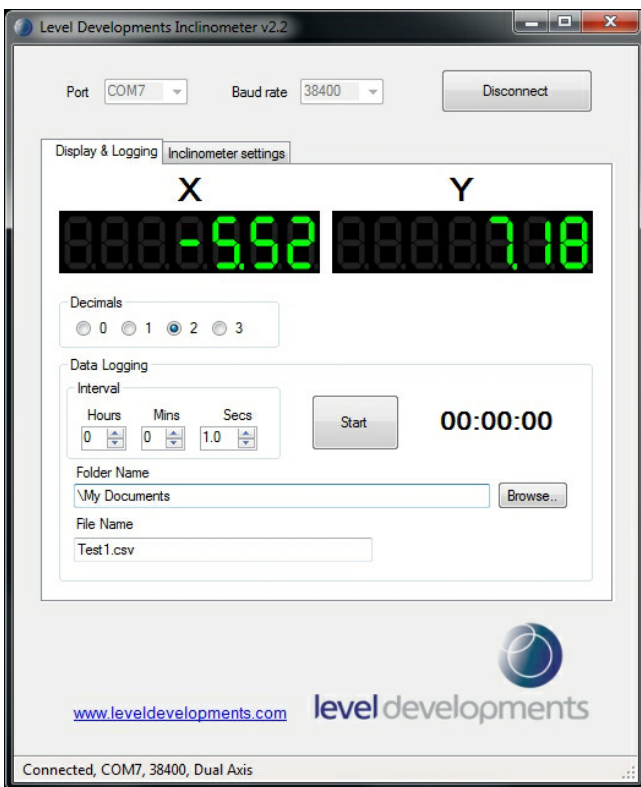

We can also offer custom software development services, please contact us for further information.

**This software is provided 'as-is', without any express or implied warranty. In no event will the authors be held liable for any damages arising from the use of this software.**